

EQUIPMENT SOLUTIONS FOR THE STEEL INDUSTRY



SAMUEL SMS-B10 AND SMS-BC10 STRAPPING MACHINES

FOR LONG STEEL PRODUCTS

Features

- Rugged structural steel tube makes it the strongest and heaviest in its class
- Top platen safety pins support the weight of the raised top platen during service work
- Cam follower guidance for positive platen motion and maintenance free operation
- Self contained hydraulic power for smooth controlled movement
- Allen-Bradley Compact logix based control system with diagnostics options available
- Automatic operation
- V532 spot weld strapping head with a reliable TIG welding system provides the best available seal joint efficiency and uses less moving parts than other systems
- Available with G9 Seal type hydraulic head and VS31 pneumatic sealless head
- Service lockout at control panel
- Hydraulic power provided by high-efficiency, whisper quiet variable displacement pump system
- Modular design concept allows greater flexibility for custom applications
- Open modular head design allows easy maintenance



SMS B10



SMS BC10

Allen-Bradley control system with service lockout



Floating head design for higher strap tension where applicable



Carriage drive for seal joint position and service mode position



Picture frame strap track for fastest cycle speeds



EQUIPMENT SOLUTIONS FOR THE STEEL INDUSTRY

Standard Equipment

- Hydraulic motions with floating head mount when required
- Dispenser options from 100 to 3000 lbs.
- Control console fully pre-wired
- Full strap track assembly
- Adjustable seal joint positioning on bundle
- Electro-hydraulic, or electro-pneumatic operation depending on head selection
- Custom configurations to suit your exact layout requirements
- Safety lockout system
- Allen-Bradley PLC standard, other control systems also available

Options

- Mobile carriage for movement in and out of line
- Seal type, spot weld and sealless heads available
- Spare parts kit
- Various machine configurations, including gantry mounted, freestanding, lateral mobile, and fixed position designs

Specifications

Operation	Automatically indexes, squares, compresses and straps or can be operated manually by pressing a single cycle button		
Machine Opening*			
Bundle sizes	Options available		
Height: Max.	(25 in.)	(650mm)	
Min.	(4 in.)	(100mm)	
Width: Max.	(30 in.)	(760mm)	
Min.	(8 in.)	(200mm)	
Strapping Size	Steel strapping: 3/4", 1-1/4" from .025 up to .044 in. thick		
Strap Joint	Up to 95% of strap strength		
Strapping Head Options	V532 Spot weld – Up to 95% joint efficiency, and 3900 lbs. of tension		
	V531 Sealless – Up to 80% joint efficiency, and up to 3900 lbs. of tension		
	G9F10 Seal type – Up to 80% joint efficiency, and up to 2900 lbs. of tension		

*Custom sizes available

Features and specifications subject to change without notice

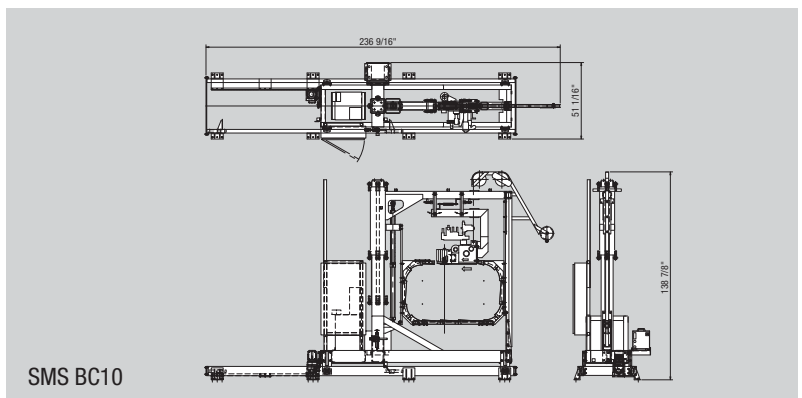
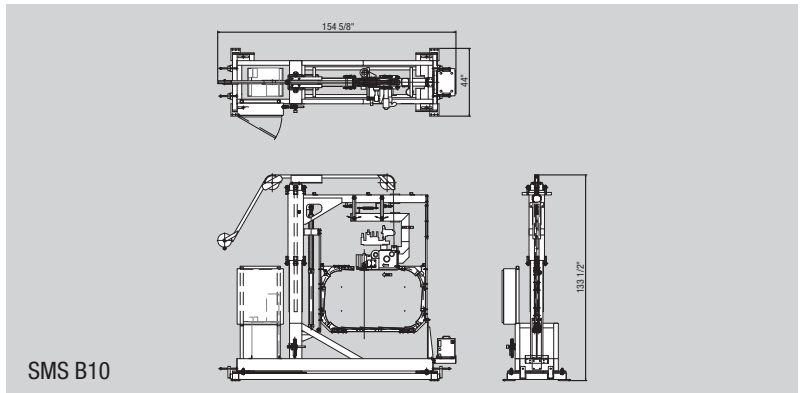

Represented By:



SMS B10-BC10-05/12-100448